

## INSTRUCTIONS FOR MODELS

SF-9700  
SF-9800

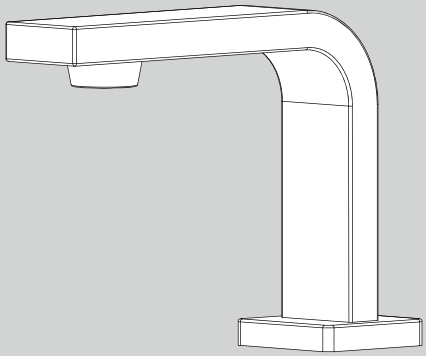

### NEED HELP?

For additional assistance or service please contact:

**SPEAKMAN®**

800-537-2107

customerservice@speakman.com

www.speakman.com

92-SF-9700-9800-02

## TOOLS AND SUPPLIES

Adjustable  
Wrench

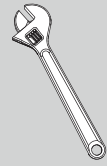

Aerator  
Wrench  
(included)



### HELPFUL TOOLS & SUPPLIES:

3/8"  
Wrench

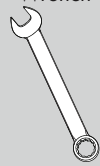

Safety  
Glasses



**1** Remove the Rubber Wire Guard (1), Metal Washer (2) and Mounting Nut (3) from the threaded Shank.

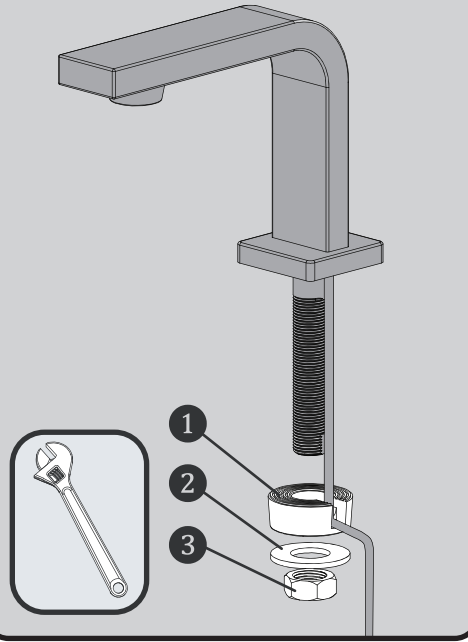

**2** Verify that the Rubber Gasket is in position and aligned to the base of the Faucet.

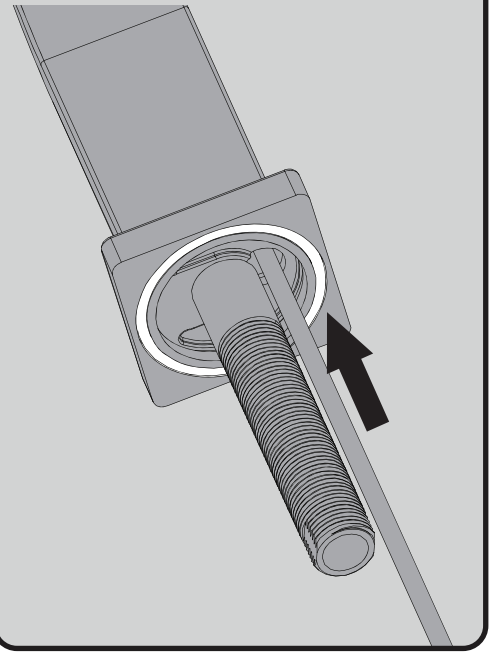

## IMPORTANT

- Do not over-tighten any connections or damage may occur.
- Be sure to read instructions thoroughly before beginning installation.
- This faucet has an operating range of 20-80 psi.

### SAFETY TIPS

Cover your drain to prevent loss of parts. Be sure to wear eye protection while cutting pipe.

### FINISH MAINTENANCE

Your new Speakman Product is designed for years of trouble-free performance. Keep it looking new by cleaning it periodically with a soft cloth. The use of harsh chemicals and abrasives may damage the finish and void the product warranty. Please be sure to only use approved cleaners. Please contact Speakman for any clarification of acceptable cleaners.

### WARRANTY

Warranty information can be found at: [www.speakman.com](http://www.speakman.com)

**3** Place the threaded shank and wire through the mounting hole. Take extra precautions to avoid pinching any wires. Lower Faucet into position.

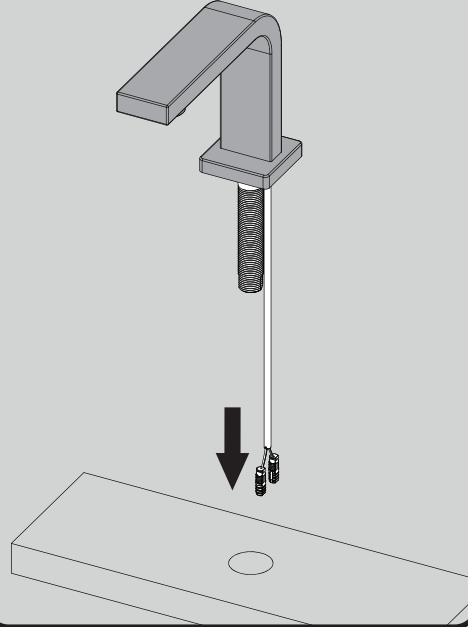

**4** From beneath, install Rubber Wire Guard (1) over the Shank and pass the Sensor Wires through the Notch to prevent pinching of wires. The Notch should be facing right. Install Metal Washer (2) and Mounting Nut (3) onto Shank. Align Faucet to desired position and wrench tighten Mounting Nut (3). Verify that Sensor Wire is not pinched.

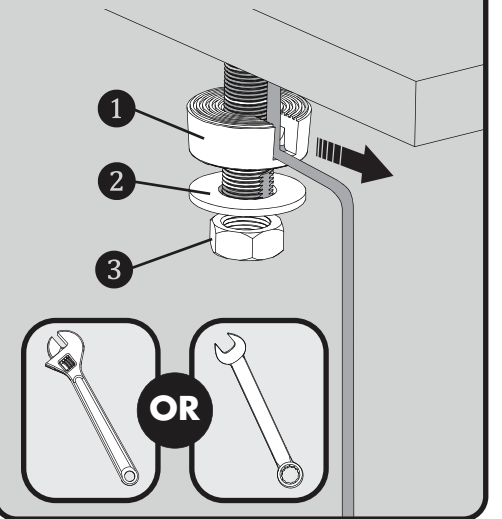

**5** Thread the Solenoid Outlet (2) directly onto the Shank (1) by hand. Verify that the Rubber Washer (3) is fully seated inside the swivel nut. Hold Faucet in position and wrench tighten the connection.

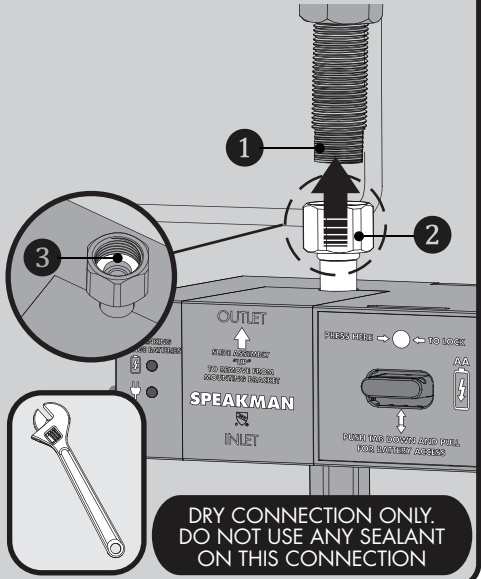

**6** Assemble "INLET" Supply Hose (1) (not supplied), to the "INLET" connection (2) of Solenoid. Wrench tighten.

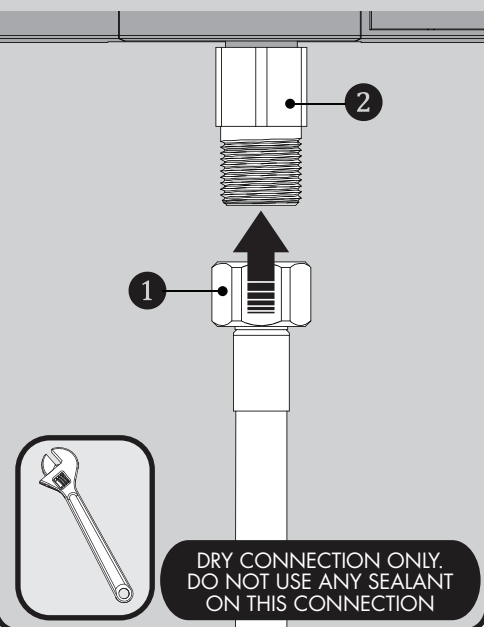

**7** Make electrical connections from the Sensor Eye to the Solenoid Assembly. Connect the Blue Male Ended Wire to the Blue Female Connection. Connect the Green Male Ended Wire to the Green Female Connection. To further aid proper alignment, there are white alignment lines on the connector ends. These alignment lines should face forward when properly installed.

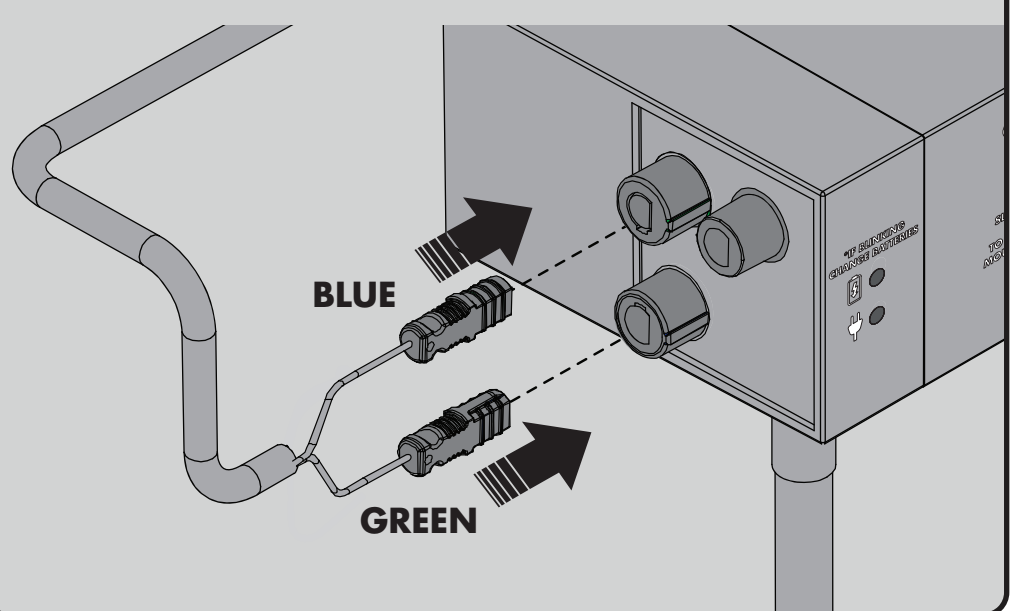

## 8 FOR BATTERY MODEL (SF-9700)

Access the interior Battery Enclosure by pressing down on the tab to release the tray holding the batteries (1). Pull out Battery Tray (2). Insert or replace the batteries with six (6) new standard 1.5v AA batteries. Ensure the position of the new batteries are aligned to the plus (+) and minus (-) symbols within the battery holder.

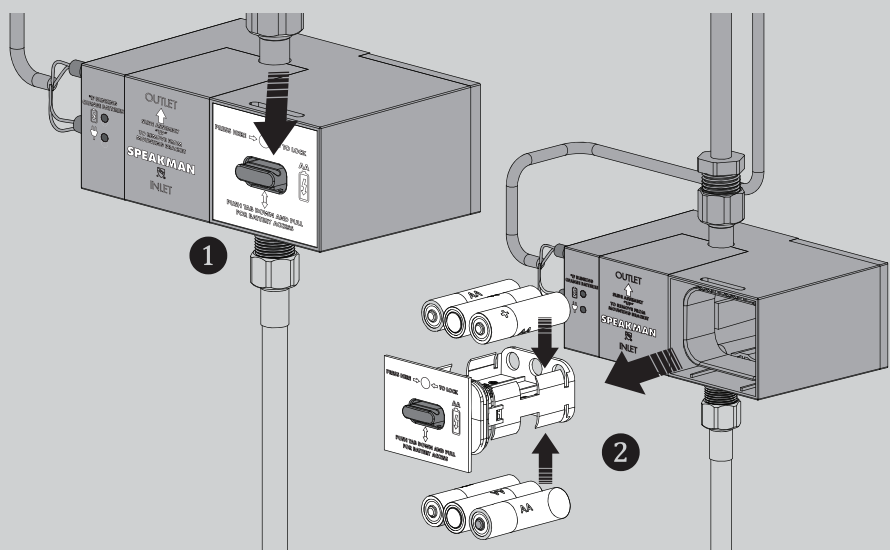

## 9 FOR A/C MODEL (SF-9800)

Verify that no batteries are present within the battery enclosure (1). Connect the A/C Adapter to the Solenoid Body (2). Plug the A/C Adapter into the wall outlet. The A/C light (3) should illuminate.

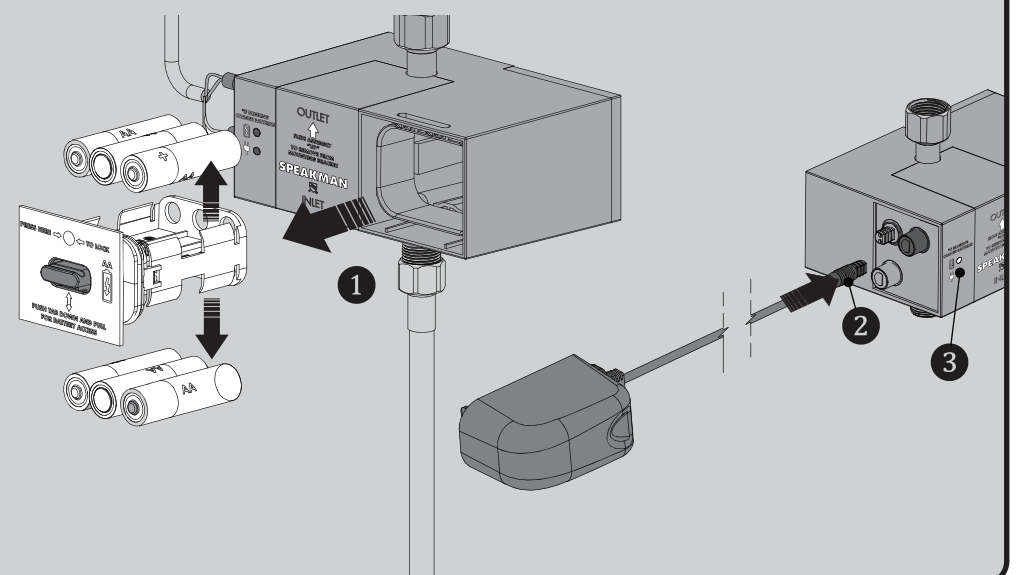

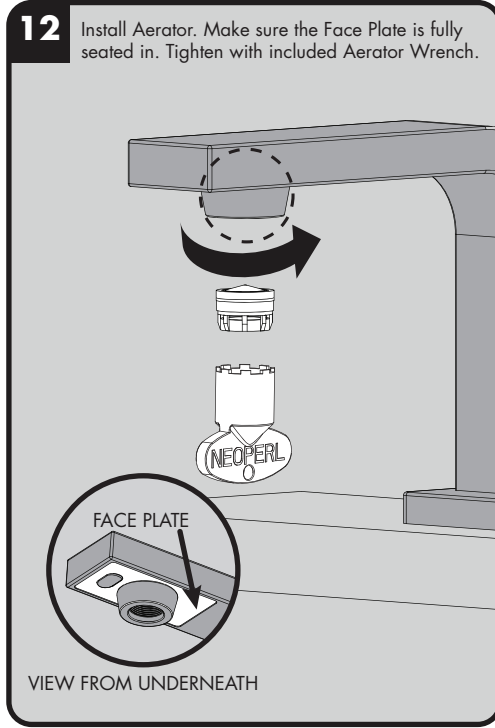
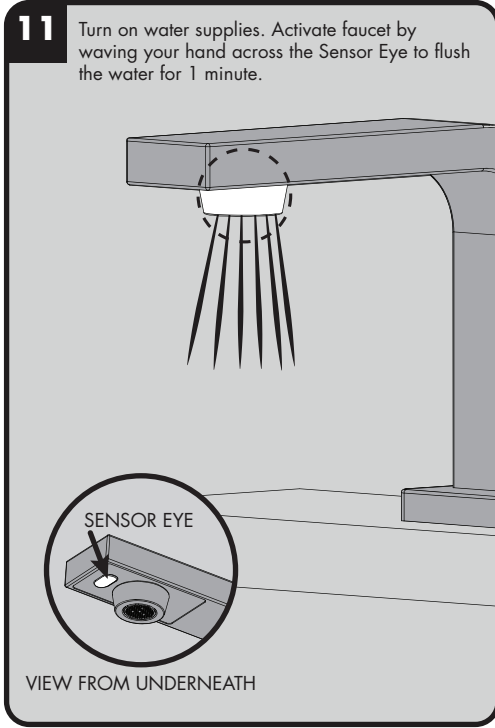
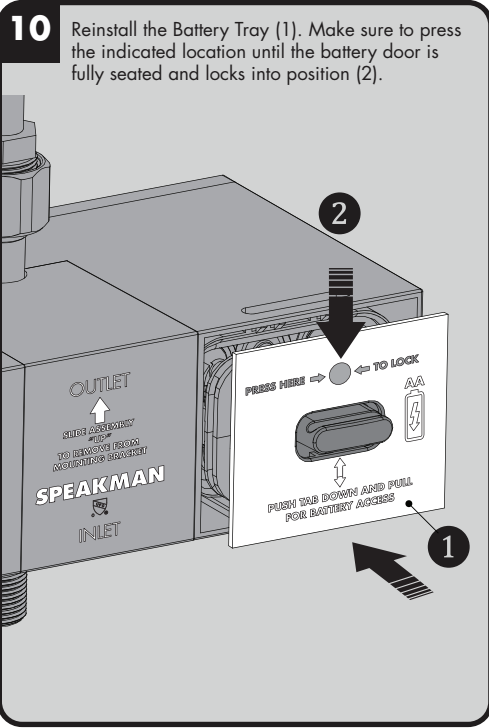

## SF-9700 / SF-9800 CARE AND CLEANING

- 1) Your SENSORFLO® Faucet is designed and engineered in accordance with the highest quality and performance standards. With proper care, it will provide years of hygienic and trouble-free service.
- 2) Periodically, the Faucet will require some minor maintenance to keep it at peak performance. There are 2 low battery indicator lights. One located on the Sensor on the Faucet body and the other located on the Solenoid Box. When the low battery light on the Sensor blinks, it indicates that the battery is low. However, the Solenoid can still function at this point. When the low battery light on the Solenoid blinks, the Solenoid will stop functioning at this point and the batteries need to be replaced immediately. To replace the batteries, follow the installation instructions in the electrical connections section of this document.
- 3) The polished chrome finish of your Faucet should be cleaned using mild soap and warm water.
- 4) Dry immediately with a soft, clean cloth for best results.
- 5) NEVER use abrasive cleaners, chemicals, alcohol or other solvents. They may damage the surfaces of the non-chrome plated finishes.

## SF-9700 / SF-9800 TROUBLESHOOTING

### **If water flow from the Faucet decreases:**

- 1) Make sure the supply stops are open.
- 2) Remove the Aerator from the spout using the outlet wrench. Operate the Faucet with outlet device removed. If water flow is acceptable, disassemble the outlet device and rinse components with clean water.

### **If no water flows from the Faucet, and**

*If you can hear a clicking sound of Solenoid opening, but no water flows:*

- 1) Verify that the HOT and COLD wall stops are completely open.
- 2) If the Battery Light within the Sensor Eye or Solenoid blinks continuously, even when the Faucet is not in use, the batteries within the Solenoid have low voltage and need replacement.

*If you do not hear a clicking sound of Solenoid opening and no water flows:*

- 1) If the Battery Light within the Sensor Eye blinks continuously, even when the Faucet is not in use, the batteries within the Solenoid have low voltage and need replacement.
- 2) Unplug connections to Solenoid for 2 minutes. Plug connections back in. The red light on the Sensor should turn on for several seconds before becoming operational. If not, check power supplies and connections.
- 3) Disconnect the existing Solenoid Assembly and connect a new Solenoid Assembly. Activate the Sensor and check for water flow. If the water flows, the existing Solenoid Assembly should be replaced.

*If the batteries have been replaced, but the Faucet still does not operate:*

- 1) Check the battery polarity and electrical connections. Make sure all electrical connections are fully inserted.
- 2) If the Faucet does not operate, replace the existing Solenoid Assembly with one you know to be functioning.

### **If the Faucet activates, but the water will not shut off:**

- 1) Hold a hand in front of the Sensor at up to 5.5" away for more than 1 minute until the water flow stops. Once the water stops, remove your hand and wait 15 seconds. Then place your hand in front of the Sensor and verify that it is operating properly.
- 2) If it is a new installation and still not working, replace the Solenoid Assembly.

## SF-9700 / SF-9800 QUESTIONS & ANSWERS

### **Q. How does the Sensorflo® Faucet work?**

**A.** It uses laser technology. The Sensor emits a non-visible beam of light. When an object enters the detection area, the Sensor signals the Solenoid Valve to open for water to flow. When an object leaves the detection area, the Sensor signals the valve to close.

### **Q. Is the Sensorflo® Faucet sensor beam adjustable?**

**A.** No, the Sensorflo® Faucet sensor beam is not adjustable. It has been factory set to factory specifications for these Faucets.

### **Q. What about water conservation?**

**A.** The Sensorflo® design directly addresses water conservation. Water savings of up to 65% are not unusual. Additional energy savings are realized by conserving hot water.

### **Q. Does Sensorflo® reduce maintenance?**

**A.** By elimination of on/off handles, control components are reduced and fittings stay cleaner longer. Only a light rinsing and wiping is required to restore the beauty of the Sensorflo® Faucets. Drip stains are eliminated. Fingerprints and soap spots on sinks and fittings are avoided. Finishes last longer and wash areas stay cleaner. Germs and bacteria are not transferred as easily making for a healthier environment.

### **Q. The chrome finish on my Faucet seems to be deteriorating. What can I do to prevent this from happening?**

**A.** Many commercial cleaning products contain harsh chemicals and abrasives. These products should not be used on any chrome-plated plumbing products. Please use only mild soap and water to clean the Faucet. Dry immediately with a soft cloth.

### **Q. Does the Sensorflo® system shut off immediately when an object leaves the sensing area?**

**A.** A very short delay of approximately 0 to 1.5 seconds occurs before water is shut off.

### **Q. Is my Faucet protected from power surges?**

**A.** Yes, Sensorflo® has been designed to have built-in power surge protection.

### **Q. If we lose power, do I have to do something to get the Faucet to operate again?**

**A.** After a power outage, the Faucet is automatically ready for operation as soon as the power comes back on.

### **Q. If I call a plumber to come and install this Faucet, will they know enough to hook it up?**

**A.** Our installation diagrams are very easy to follow.

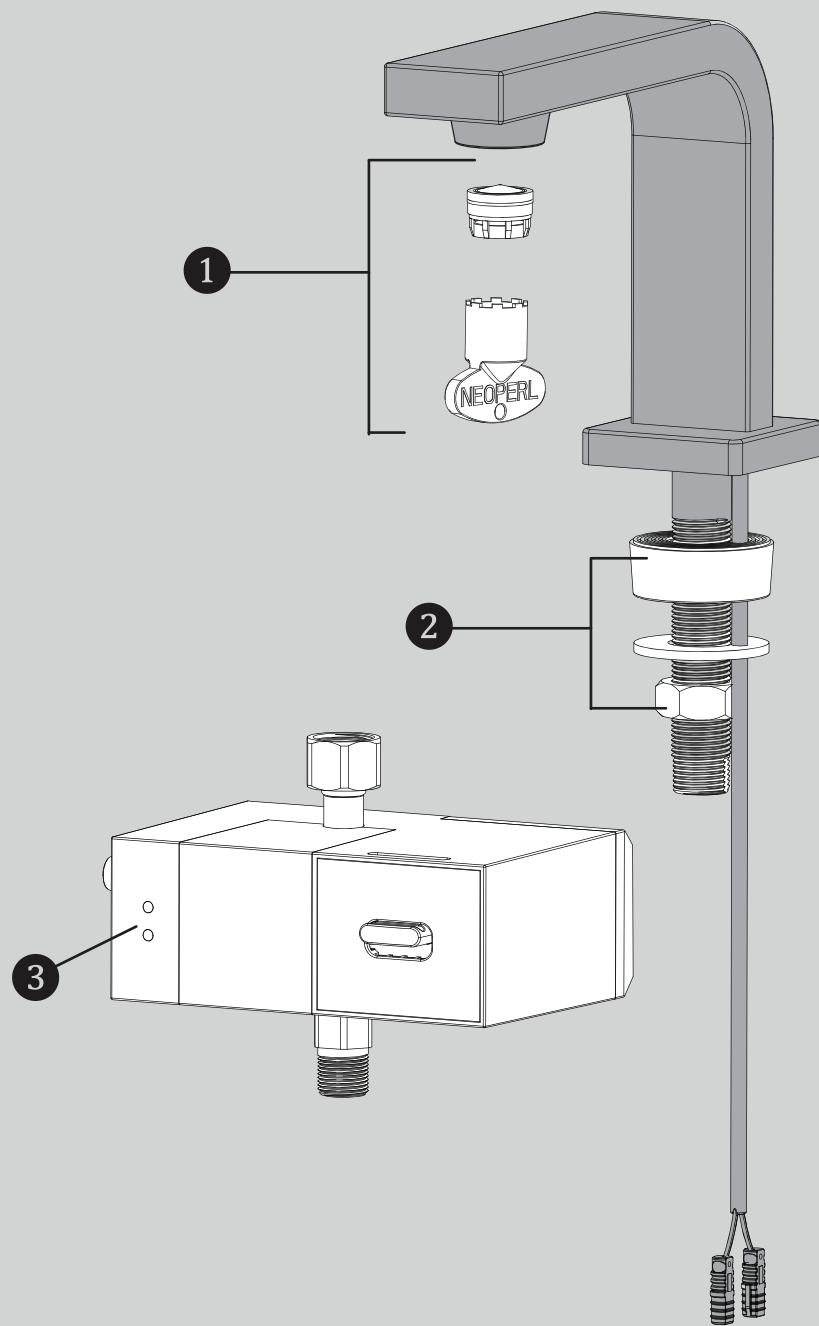

ITEM NO.	PART NO.	DESCRIPTION
1	RPG05-108059	0.5GPM AERATOR REPAIR KIT
2	G05-0650	SPOUT MOUNTING HARDWARE GROUP
3	RPG76-108060	SOLENOID BOX ASSEMBLY (NO BATTERY)

SF-9700 / SF-9800 ROUGH-IN DIAGRAM

NOTES:

COMPLIANCE:

ASME A112.18.1/CSA B 125.1

FLOW DATA:

- 0.5gpm (1.9 L/min)

CONNECTIONS:

Supply Connection:  
9/16"-24 UNF Connection

LAVATORY ROUGH-IN

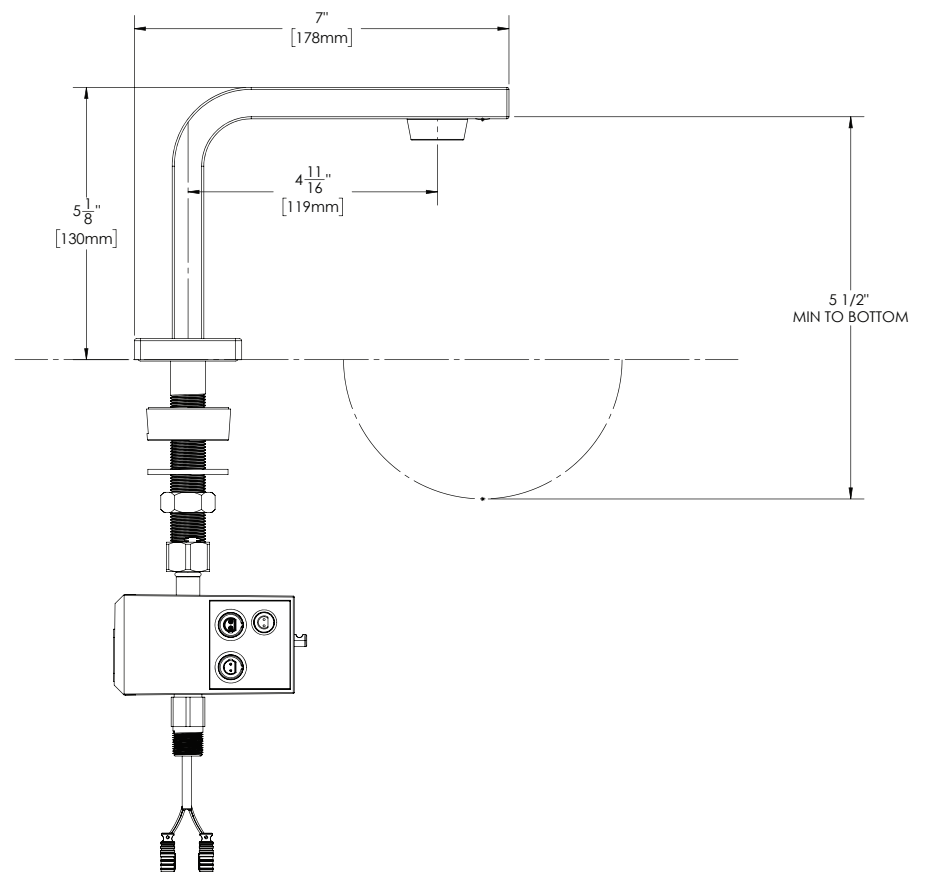
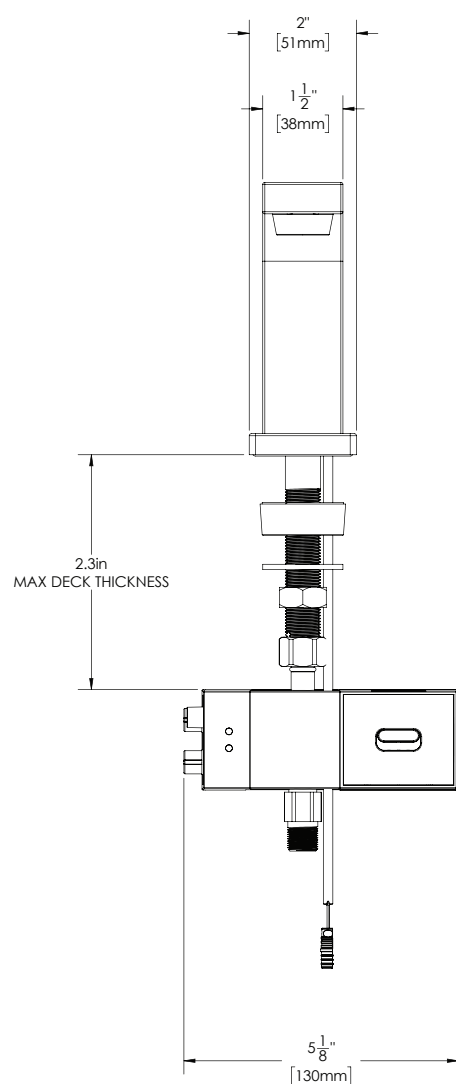
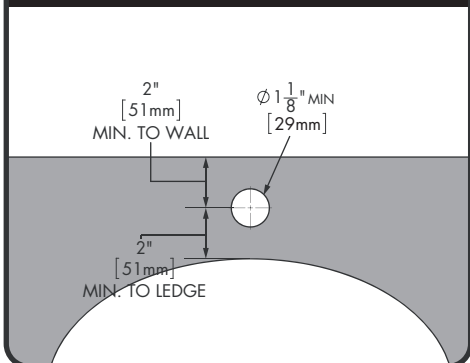

ALL DIMENSIONS ARE IN INCHES (MILLIMETERS) UNLESS OTHERWISE SPECIFIED. DIMENSIONS SUBJECT TO CHANGE WITHOUT NOTICE.